



# HD 9008TR - HD 9009TR HD 9007



# TEMPERATURE AND HUMIDITY TRANSMITTERS, MULTIPLATE RADIATION SHIELD

## HD9008TR - HD9009TR RH AND TEMPERATURE TRANSMITTERS

### CHARACTERISTICS

The HD9008TR and HD9009TR are single block RH and temperature microprocessor transmitters, temperature configurable. The HD9008TR is a passive transmitter with a 4...20mA output and 7...30Vdc power supply; the HD9009TR is a transmitter with a 0...1V standard voltage output (other outputs available on demand) and 7...30Vdc power supply. Sensors are mounted at the end of a plastic tube: a capacitive humidity sensor and a Platinum temperature sensor (100Ω @0°C).

The instrument can be reprogrammed by means of a key, and no jumper or potentiometer actions are required. The humidity input can be recalibrated by using two saturated solutions: the first one at 75%, the second one at 33%; the 0%RH...100%RH relative humidity range is fixed, 4mA (or 0Vdc) correspond to 0%RH, 20mA (or 1Vdc) equal 100%RH.

Temperature standard configuration is -40...+80°C for the HD9008TR and -40...+60°C for the HD9009TR, corresponding to 4...20mA and 0...1Vdc, respectively.

The user can configure the temperature output in ranges different from the standard one by means of a Pt100 simulator or of a set of fixed resistances, provided that it is included in the -40°C...+80°C range with a minimum amplitude of 25°C. Two LEDs give alarm indications (temperature exceeding set range, sensor breakage or short-circuit) and help the operator when programming.

An out-of-standard temperature operating range can be requested when placing the order.

*Important Warning: probes work in the -40°C...+80°C temperature range. Outside this range data are not correct; electronics is designed to operate in this range.*

### SENSORS

The humidity sensor is a condenser which dielectric is made up by an hygroscopic polymer. As water dielectric constant is approximately 80, you'll get a strong change in capacity as the humidity content of this polymer changes. The advantages of this kind of sensor are: good linearity, insensitivity to temperature changes, fast response time and long-lasting life. The sensor temporarily loses its accuracy if some condensation develops on its surface (the transmitted value is higher than the real one because of an increase in effective capacity).

The temperature sensor is a Platinum resistance thermometer (100Ω @0°C). The Pt100 resistance variation is transformed into a current or voltage signal, linear to temperature.

### SIGNAL TRANSMISSION

The electronic circuit design provides the signal to increase linearly as humidity and temperature raise.

In presence of cables transmitting high currents or machines causing electromagnetic noises, the transmitter connection cables have to be placed in a separate raceway, or far from them, to prevent these noises. It is recommended to use a shielded cable for the connections of instruments having a voltage output (HD9009TR).

### INSTALLATION AND ASSEMBLY

Figures 1 and 2 show the connection diagram of the two models. RRH and R°C represent the current input of any device connected to the 4...20mA loop, that is: an indicator, a controller, a data logger or a recorder. In figure 2, "Vin%RH and Vin°C" symbols have the same meaning.

Accuracy in measuring does not depend on the transmitter position. However, it is suggested to install the transmitter with the sensor faced downwards (where possible) to reduce dust deposit on the sensor protection filter. The transmitter shall not be mounted next to doors, in draughtiness, in areas with scarce air circulation, or near a heat source, as heating air involves a decrease of relative humidity (the quantity of available water vapour being equal).

Protection degree: IP54.

**Ensure that the sensor is compatible with the atmosphere where it is installed.**

Follow these procedures to access the transmitter terminal board (see fig.3): Unscrew grommet "A", take off rubber bulb "B" and unscrew bottom "C". Insert the cable through A, B and C elements and connect it to the terminal board. Hold the cable firmly while screwing grommet "A" to avoid twisting.

### PROGRAMMING

HD9008TR and HD9009TR relative RH and temperature transmitters are factory calibrated. The HD9008TR is provided with a 4...20mA current output, while the HD9009TR with a 0...Vdc voltage output.

**In the HD9008TR standard configuration, 4mA correspond to 0%RH and -40°C, while 20mA equal 100%RH and +80°C.**

**In the HD9009TR one, 0Vdc corresponds to 0%RH and -40°C, while 1Vdc equals 100%RH and +80°C.**

The user can re-calibrate the RH probe holding the 0%...100%RH range and setting a different range for temperature, as long as it is within -40 and +80°C limits.

Figure 4 shows the transmitter programming elements.

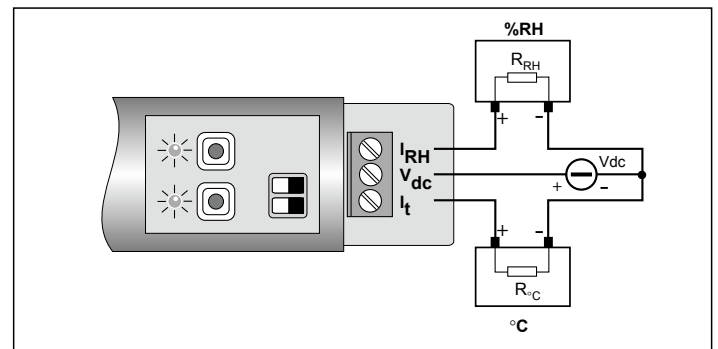

Fig. 1

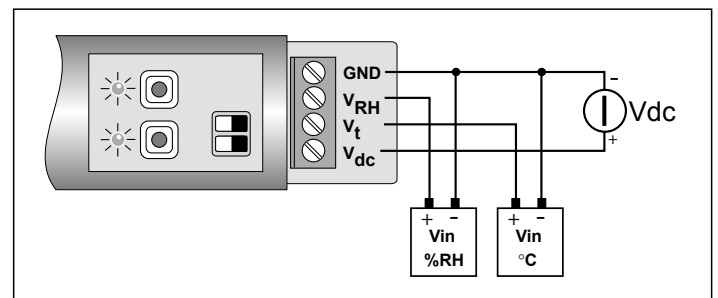

Fig. 2

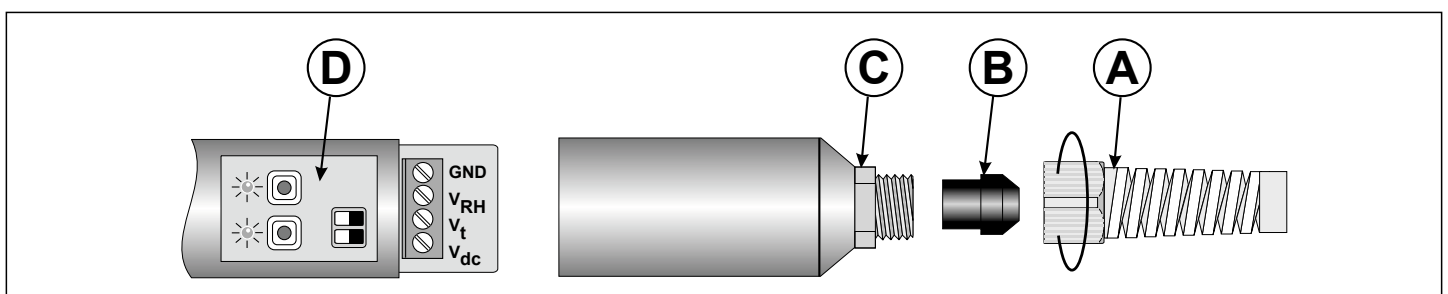

Fig. 3

## Humidity Sensor Calibration

The following accessories are needed.

HD9008TR model: a 7...30Vdc continuous voltage power supply, a precision ammeter with a 0...25mA min. range.

HD9009TR: a 7...30Vdc continuous voltage power supply, a precision voltmeter with a 0...1Vdc min. range.

The calibration of the humidity sensor is carried out at two fixed points: at 75.4%RH – **always as first point** – and at 33%RH – second point.

### Procedure:

- To access the panel board, unscrew grommet "A" (see fig. 3) and hold the cable firmly to avoid twisting. Take off the rubber bulb and unscrew the bottom of the instrument.
- Connect the wires to provide the instrument with power supply, as shown in the connection diagrams (Fig. 5: HD9008TR and Fig.6: HD9009TR).
- Insert the probe in the container with the saturate solution at 75%RH and wait **30 minutes at least**. Probes and solutions have to be at the same temperature.
- Turn 75%RH dip-switch on ON.
- Press the CAL%RH little key and **hold it down for 5 seconds, at least**, until the corresponding LED does not flash. Now the little key can be released: the LED will remain on. A built-in sensor compensates the temperature difference of the solution compared with 20°C.
- Turn the 75%RH dip-switch on OFF.
- Put the probe in the container with the saturate solution at 33%RH and **wait for 30 minutes, at least**. Probes and solutions have to be at the same temperature.
- Turn the 33%RH dip-switch on ON.
- Press the CAL%RH small key and **hold it down for 5 seconds, at least**, until the corresponding LED is not off. Now the little key can be released. If the solution is at 20°C, the output will equal 9.28mA (in HD9008TR model) and 0.330V (in HD9009TR model). If the solution is at a different temperature, the output will correspond to the value listed in the following table:

°C	10	15	20	25	30	35	40	45	50
%RH	33.4	33.3	33	32.7	32.4	32	31.6	31.1	30.5
mA	9.34	9.33	9.28	9.23	9.18	9.12	9.06	8.98	8.88
V	0.334	0.333	0.330	0.327	0.324	0.320	0.316	0.311	0.305

- Turn the 33%RH dip-switch on OFF again.
- Re-close the instrument: re-screw the bottom, put the rubber bulb again at its place and screw the grommet: hold the cable firmly to avoid twisting it.
- The calibration of the RH probe is finished.

**Important Note: the first calibration point has to be always at 75%RH**

### Programming of Temperature Operating Range

The following accessories are needed.

For HD9008TR: a 7...30Vdc continuous voltage power supply, a precision ammeter with 0...25mA minimum range.

For HD9009TR: a 7...30Vdc continuous voltage power supply, a precision voltmeter with 0...1Vdc minimum range.

Pt100 simulator or a set of precision resistances.

### Procedure:

- To access the panel board, unscrew grommet "A" (see figure 3) and hold the cable firmly to avoid twisting. Take the rubber bulb off and unscrew the bottom of the instrument.
- Unscrew the sensor protection filter.
- Unsolder the Pt100 sensor (the narrowest one) and in place of it, solder the output wires or those of a Pt100 simulator or of a precision resistance, as shown in figures 7 and 8. Then wait a few seconds for the junction to get cold.
- Set the Pt100 simulator at the temperature corresponding to the scale upper value. For example, if you want to configure the -10°C...+80°C range, the simulator has to be set at -10°C; the equivalent resistance value will be 96.09Ω. If the calibration is carried out with a fixed resistance, connect a 96.09Ω fixed resistance to the terminals to which the sensor was soldered.
- Wait 10 seconds until the measurement becomes steady, **press the "CAL °C" key (calibration) and hold it down for min. 5 seconds**, until the LED first flashes (once) and then remains on.
- Set the Pt100 simulator at the temperature value provided for the full scale. According to the above example, the simulator will be set at +80°C; the equivalent resistance value will be 130.89Ω; if the calibration is carried out with a fixed resistance, a 130.89Ω fixed resistance will have to be connected to the terminals to which the sensor was soldered.

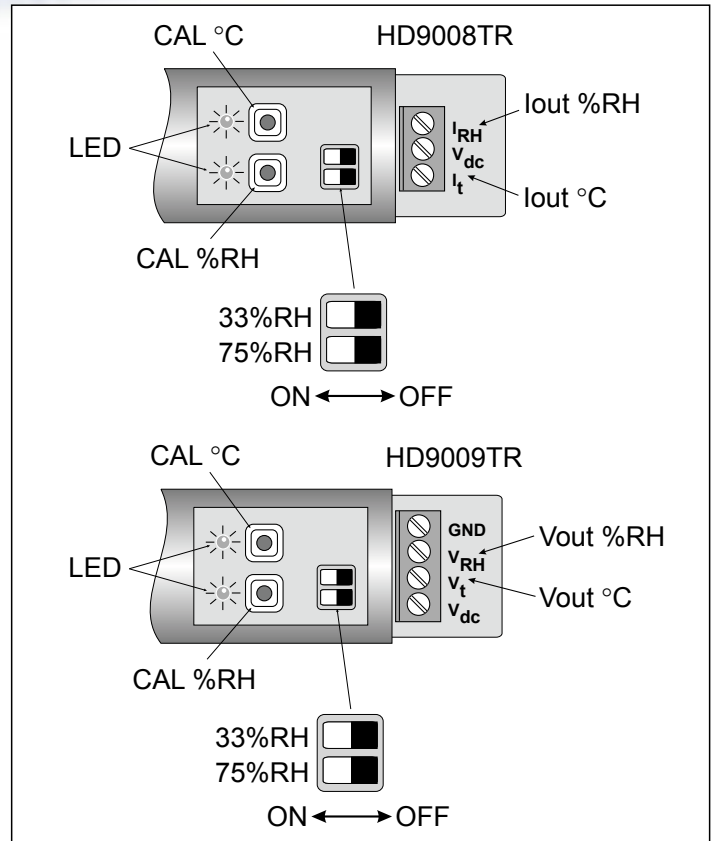

Fig. 4

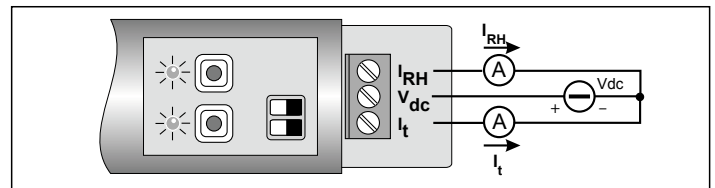

Fig. 5

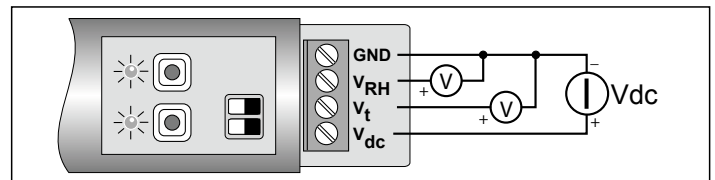

Fig. 6

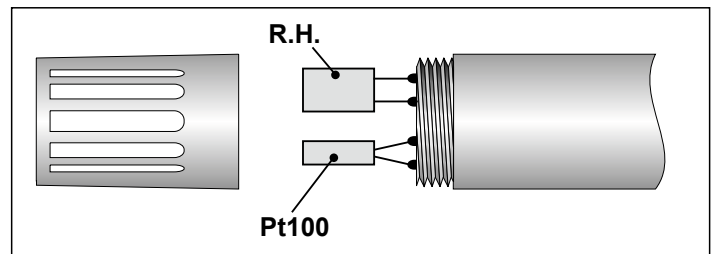

Fig. 7

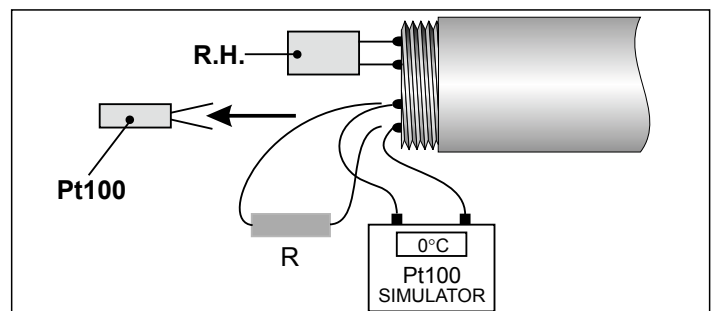

Fig. 8

7. Wait 10 seconds until the measurement becomes steady, **press the "CAL °C" key (calibration) and hold it down for min. 5 seconds**, until the LED is off. **When you release the key**, the LED will flash twice to confirm that programming took place. Now the procedure is over.
8. Check that the configuration corresponds to the requested specifications, by setting the simulator (or connecting the precision resistances) at the values corresponding to the upper and full scale value and by checking the output with the ammeter 8HD9008TR) or with the voltmeter (HD9009TR).
9. Solder again the temperature sensor.
10. Insert again the sensor protection filter, screw the bottom, put the rubber bulb again at its place and screw the grommet holding the cable firmly to avoid twisting.
11. The temperature output programming is over.

Saturate reference solutions are available for RH calibration. Calibration is suggested every 12/18 months for instruments with continuous operation, according to the environment they are working in. **Check that the sensor and the atmosphere where it is employed be compatible, above all in case of aggressive environments** (they might corrode the sensor).

## HD9007 MULTIPLATE RADIATION SHIELD

### Characteristics

Luran S777K (BASF) antistatic UV-resistant thermoplastic material with low thermal conductivity and high reflection.

White power-painted anticorrosive aluminium support bracket. Stainless steel U-bar mounting bracket for shafts from 25 to 44mm.

Dimensions: external Ø : 130 mm.

Height, excluding bracket: HD9007 A1: 190 mm, weight: 640 gr.

HD9007 A2: 240 mm, weight: 760 gr.

Sensor fixing ring nuts: Ø 27 mm, Ø 25 mm on demand when ordering.

HD9007 ring-shield is suitable to protect temperature and RH/temperature sensors used in weather stations from solar radiations, rain and wind.

## ORDERING CODES

**HD9008TR:** dual passive RH and temperature microprocessor transmitter  
4...20mA outputs in 0...100%RH and -40...+60°C ranges.

**HD9009TR:** dual RH and temperature microprocessor transmitter.  
0...1V output in 0...100%RH and -40...+60°C ranges.

**HD9007 A1:** 12-ring protection L=190 mm complete with mounting brackets.

**HD9007 A2:** 16-ring protection L=240 mm complete with mounting brackets.

**HD75:** saturated salt solution 75% R.H. with adapter M 24x1,5

**HD33:** saturated salt solution 33% R.H. with adapter M 24x1,5

**HD9008.21.1:** holder for vertical sensor, wall distance 250mm, hole Ø 26.

**HD9008.21.2:** holder for vertical sensor, wall distance 125mm, hole Ø 26.

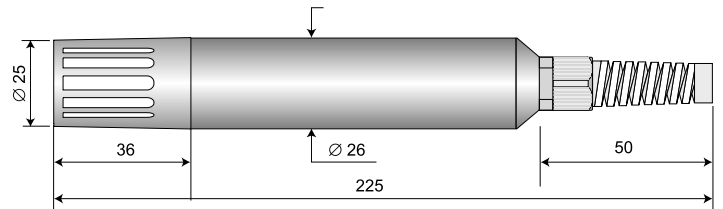

TECHNICAL DATA		HD9008TR	HD9009TR
Electronics Working Temperature		-40...+80°C	
Sensor Working Temperature		-40...+80°C	
Transmitter Power Supply		7...30Vdc (4...20mA)	7...30Vdc (2mA)
Capacity		300 pF typ.	
HUMIDITY	Measuring Range	5...98%RH	
	Accuracy at 20°C	±2%RH (5...90%RH) ±2.5%RH (for the remaining range values)	
	Response time at 63% of final variation	3 min. with filter; 6s without filter	
	Output Signal	0%RH = 4.0mA 100%RH = 20.0mA	0%RH = 0.00 Vdc 100%RH = 1.00 Vdc (*)
	Load Resistance	$R_{Lmax} = \frac{(Vdc - 7)}{22mA}$	$R_{min} = 10K\Omega$
TEMPERATURE	Measuring Range – Standard Configuration - (**)	-40...+80°C	
	Accuracy	±0.1°C ±0.1% of measurement	
	Response time at 63% of final variation	60s with filter; 5s without filter	
	Output Signal	-40°C = 4.0mA +80°C = 20.0mA	-40°C = 0.00 Vdc +80°C = 1.00 Vdc (*)
	Load Resistance	$R_{Lmax} = \frac{(Vdc - 7)}{22mA}$	$R_{min} = 10K\Omega$
Dimensions		Ø 26 x 225mm	
Cable Dimensions			
Maximum Length (***)		200m	10m
Wire Min. Section		20 AWG - 0.5mm²	
Cable Max. Diameter		Ø5mm	

(\*) For HD9009TR models, 0...5Vdc, 1...5Vdc, 1...6Vdc, 0...10Vdc voltage outputs can be provided on ordering.

(\*\*) Out-of-standard measuring ranges have to be requested when ordering and have to be re-programmed with a Pt100 simulator.

(\*\*\*) Use screened cables.

