



ACTIVE TRANSMITTER AND RELATIVE HUMIDITY HYGROSTAT

Description

The HD 2017T... is an active transmitter and microprocessor-controlled relative humidity hygrostat with display of the value detected by the sensor and display of the parameters during programming. The transmitter converts the humidity value into a linear current or voltage signal. The outputs available are in current 0...20mA or 4...20mA and in voltage 0...1V or 0...10V. The selection is made by means of a jumper. Linearisation, with a digital technique, allows excellent precision and stability to be obtained. The absence of trimmers, potentiometers, etc. makes instrument calibration very simple: it requires only operation on the keyboard without having to open the instrument. The humidity input can be recalibrated using two saturated solution: the first with 75%R.H., the second with 33%R.H. The relative humidity range 0%R.H...100%R.H. is fixed: depending on the solution used, the value 0%R.H. corresponds to 0mA, 4mA or 0V, while 100%R.H. corresponds to 20mA, 1V or 10V. Temperature compensation of the humidity measurement is obtained with a sensor in the probe. The ▲ symbol on the display flashes if the probe temperature is lower than -50°C, higher than +150°C or if the temperature sensor is broken. Likewise, the display gives an "ERR" (error) indication if the humidity sensor is not inserted, not calibrated or faulty. The HD 2017T... also acts as an ON/OFF regulator for humidification or dehumidification: for this reason it is provided with a relay with a free potential contact at output. A LED on the front panel of the instrument indicates the energised or de-energised status of the relay.

Important note: the relative humidity sensor can work in the temperature range -40...+150°C. Outside this range it can work till +180°C for brief periods or in special execution.

Installation and connection

Figures 3, 4 and 5 show the mechanical dimensions of the transmitter while Fig.6 shows the holes for securing the container. Fig.1 shows the wiring diagram of the transmitter configured with the current output. The load represents any device inserted in the current loop, that is: an indicator, a controller, a data logger or a recorder. The relative humidity measurement precision does not depend on the position of the transmitter. However it is advisable to install the transmitter in such a way that the sensor is facing downwards to minimise the accumulation of dust on the filter that protects the sensor. The transmitter must not be installed in the vicinity of a source of heat or cold, since heating or cooling of the air cause a decrease or an increase of the relative humidity (with the same amount of water vapour present), near doors, in the presence of draughts or in areas where there is no movement of air.

During use, check the compatibility of the sensor with the atmosphere in which it is installed.

Assembly

The instrument is offered in three different configurations to satisfy every application requirement:

TO horizontal version, generally for installation in a channel; a sliding joint is available for fixing in channels or on walls with a 1/2" gas thread.

TV vertical version for installation on the wall.

TC version with cable. The humidity probe is connected to the electronics by means of a cable of various lengths and it may operate in a temperature range of -40...+150°C.

For the electrical connection there are two grommets PG7. See Fig.1 for the connections.

Attention: in TC models the sensor and the electronics have the same serial number, they cannot be exchanged with other transmitters unless the instrument is recalibrated in line with the new probe.

Setting the SET POINT

The HD 2017T... is provided with a relay with a free potential output contact. A LED on the front panel of the instrument lights up when the relay is energised. The choice between humidification and dehumidification is based on the ON and OFF values of the relay, as indicated in the table and in the graphs below.

Humidification: OFF is used to set the **maximum desired humidity value** and **ON (lower than OFF)** to set the amplitude of hysteresis. As shown in the example in Fig.2A, starting from low humidity values, the relay contact is closed (humidifier operating) and remains closed until the OFF value of 55%R.H. When this value is exceeded, the contact opens and remains open until the humidity falls below the ON value of 50%R.H.; when this second value is reached, the relay contact closes and commands the new humidification.

Dehumidification: OFF is used to set the **minimum desired humidity value** and **ON (higher than OFF)** to set the amplitude of hysteresis. As shown in the example Fig.2B, starting from high humidity values, the relay contact is closed (dehumidifier operating) and remains closed until the OFF value of 45%R.H. When this value is exceeded, the contact opens and remains open until the

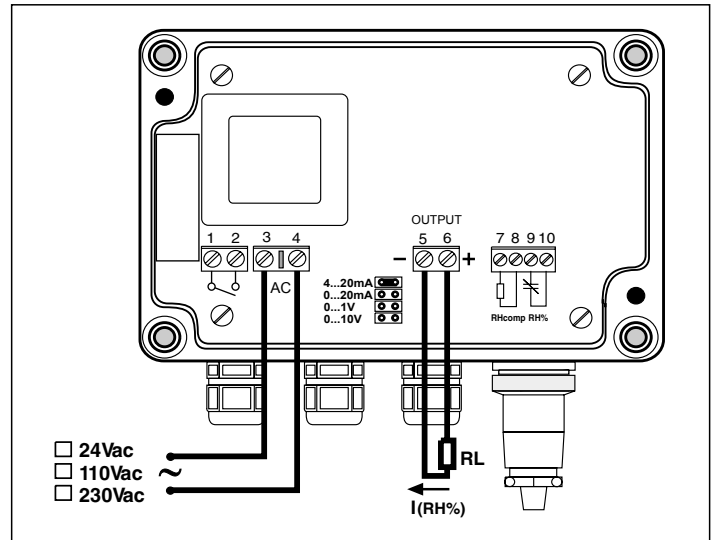

Fig. 1 Wiring diagram of the HD 2017T...

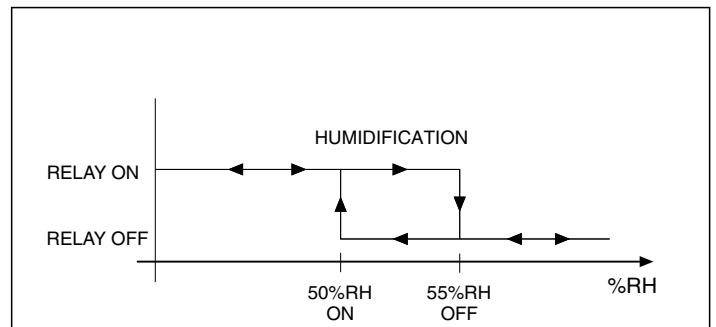

Fig. 2A Relay output with humidification function

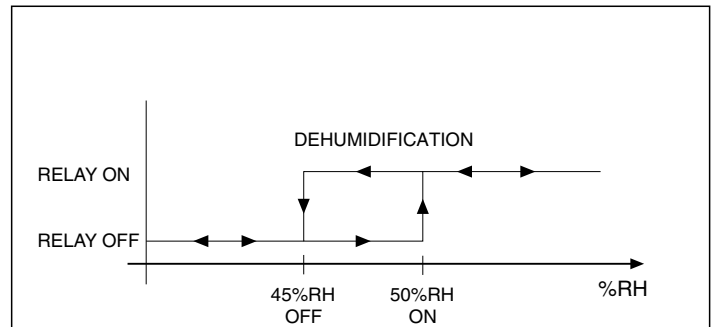

Fig. 2B Relay output with dehumidification function

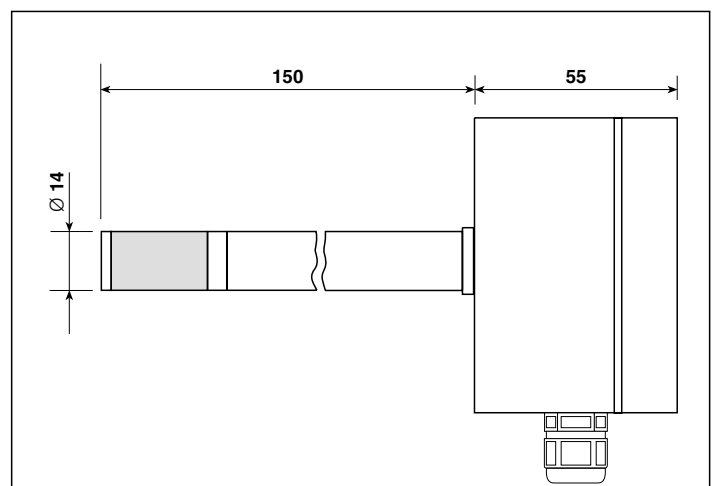

Fig. 3 Mechanical dimensions version TO

humidity rises above the ON value of 50%R.H.; when this second value is reached, the relay contact closes and commands the new dehumidification.

| | Setting the SET POINT | Hysteresis |
|---------------------------|---|-----------------|
| Humidification (Fig.2A) | ON lower than OFF (e.g. ON=50%R.H. and OFF=55%R.H.) | OFF-ON (5%R.H.) |
| Dehumidification (Fig.2B) | ON higher than OFF (e.g. ON=50%R.H. and OFF=45%R.H.) | ON-OFF (5%R.H.) |

Procedure

1. Hold down the **SET** key for at least 5 seconds: from normal operating mode you enter the procedure for setting the set points (a letter "m" on the display indicates that the SET POINT parameters are being set); the display indicates first "SET" and then "ON" to inform you that you are about to modify the relative humidity value at which the relay is energised.
2. Set the desired value with the **Up** (▲) and **Down** (▼) keys.
3. At this point the word "OFF" appears to indicate that you are about to modify the relative humidity value at which the relay is de-energised.
4. Set the desired value with the **Up** (▲) and **Down** (▼) keys.
5. Press the **SET** key to confirm. The procedure is ended: return to normal operating mode.

Notes

- A) The two relay intervention thresholds must differ by at least one percentage point: otherwise the instrument will indicate error E1 and the setting procedure will be repeated from the start.
- B) If more than 30 seconds are allowed to pass between pressing one key and the next during the SET procedure, the instrument leaves the procedure without modifying the data in the memory to avoid incorrect settings.

Calibration of the relative humidity sensor

The HD 2017T... is calibrated in the factory so, generally, no adjustment by the user is needed. For calibration, 75% and 33% saturated solutions are required.

Procedure

1. Insert the probe in the container with the 75% saturated solution for relative humidity. **The first calibration point is always 75%R.H.**
2. Hold down the **CAL** button for at least 5 seconds: the letters **CAL** appear on the display followed by the indication **-75-**.
3. Wait at least 30 minutes.
4. Hold down the **CAL** button for at least 5 seconds to confirm the value at 75%R.H.

The indication **-33-** will appear on the display.

5. Insert the probe in the container with the 33% saturated solution for relative humidity.
6. Wait at least 30 minutes.
7. Hold down the **CAL** button for at least 5 seconds to confirm the value at 33%R.H. The procedure is ended: return to normal operating mode.

Notes

- A) If the calibration points are not accepted by the instrument, the error message **E2** will appear on the display and the setting procedure will be repeated from the start.
- B) **It is not possible to calibrate only one of the two points.**



Holder HD 9008.21.2 + HD 9008.26/14 125 mm.

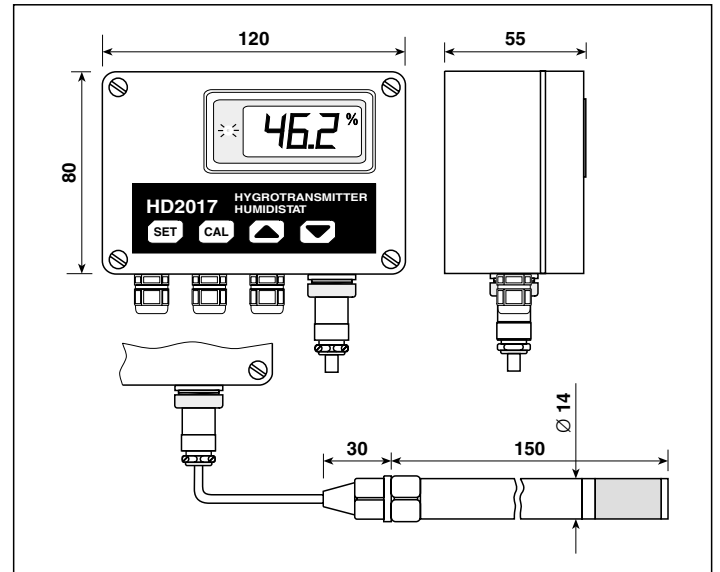

Fig. 5 Mechanical dimensions version TC

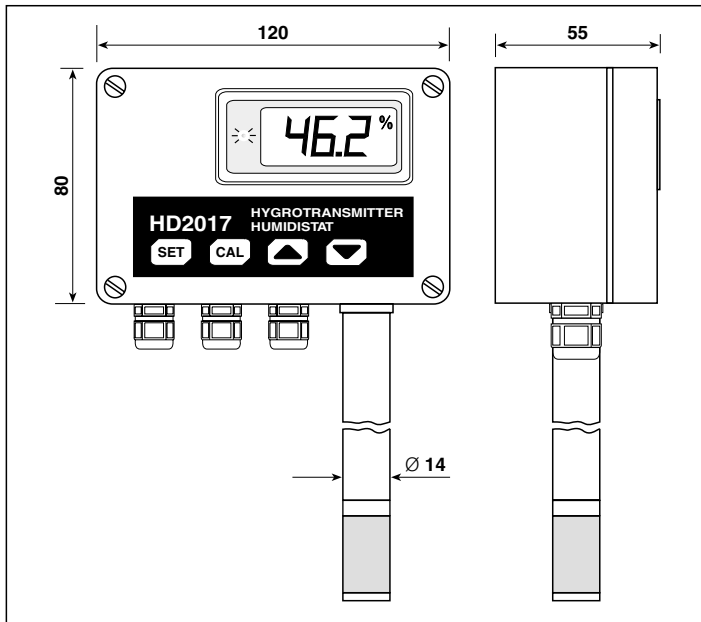

Fig. 4 Mechanical dimensions version TV

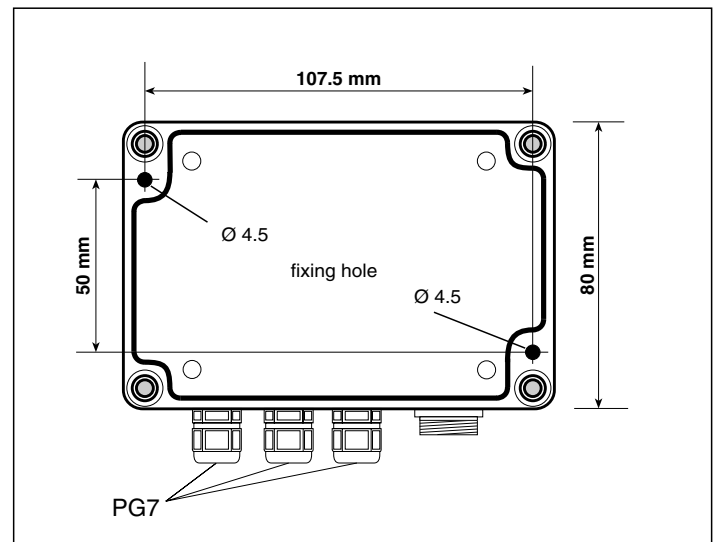

Fig. 6 Fixing holes

Technical data (@ 20°C and 24Vac)

| | | | |
|---|---|--|---|
| Relative humidity input | Sensor model | MK 33 | |
| | Capacity | 300pF typ. | |
| | Accuracy at 20°C | ±2% (5...90%) ±2.5% (in the remaining field) | |
| | Relative humidity work range | 5...98%R.H. | |
| | Probe temperature work range | -40...+150°C | |
| | Cable length | TC Version = 1.5 m, 5 m or 10 m | |
| | Sensor maximum static working pressure | 20 bar | |
| During use, check the compatibility of the sensor with the atmosphere in which it is installed | | | |
| Temperature compensation | KTY sensor (1K Ω @ 25°C) | -40...+150°C | |
| Calibration | Recognition of the value of the saturated solutions - temperature range | 10...50°C | |
| Transmitted signal output | 4...20mA 0...1V | 0...20mA 0...10V | 0...100%R.H. |
| | 22mA (The display indicates "ERR") | | In case of incorrect programming, probe disconnected or not calibrated. |
| | Linearisation | | Digital |
| | Current output | | Load resistance \leq 500 Ω |
| | Voltage output | | Load resistance \geq 100K Ω |
| Alimentazione | Voltage | 24Vac \pm 10%, 50...60Hz (on request 115Vac and 230Vac) | |
| | Absorption | 3VA | |
| Power supply | Resistive | 3A / 230Vac (resistive load) | |
| | Inductive | 1.5A / 230Vac (inductive load) | |
| Response time (*) | Without filter | 6 seconds | |
| | With filter | 3 minutes | |
| Electronics working temperature | | -20...+70°C | |
| Housing | Degree of protection | IP65 | |

(*) Time required to reach 63% of the final variation

Order codes

HD 2017 TO/1: active transmitter and relative humidity hygostat with display, output 0...20mA, 4...20mA, 0...1V or 0...10V. Horizontal fixed probe for channel installation L=130 mm.

HD 2017 TV: active transmitter and relative humidity hygostat with display, output 0...20mA, 4...20mA, 0...1V or 0...10V. Vertical fixed probe for wall installation.

HD 2017 TC/1: active transmitter and relative humidity hygostat with display, output 0...20mA, 4...20mA, 0...1V or 0...10V. Probe L=130 mm for direct connection to the instrument with a cable L=1.5 metres.

HD 2017 TC/2-5: active transmitter and relative humidity hygostat with display, output 0...20mA, 4...20mA, 0...1V or 0...10V. Probe L=330 mm for direct connection to the instrument with a cable L=5 metres.

HD 2017 TC/2-10: active transmitter and relative humidity hygostat with display, output 0...20mA, 4...20mA, 0...1V or 0...10V. Probe L=330 mm for direct connection to the instrument with a cable L=10 metres.

HD75: saturated salt solution 75% R.H. with adapter M 12x1

HD33: saturated salt solution 33% R.H. with adapter M 12x1

HD9008.21.1: holder for vertical sensor, wall distance 250mm, hole \varnothing 26.

Use with reduction HD9008.26.14

HD9008.21.2: holder for vertical sensor, wall distance 125mm, hole \varnothing 26.

Use with reduction HD9008.26.14

HD9008.26/14: reduction for \varnothing 26 and \varnothing 14mm holes, for HD9008.21.1 and HD9008.21.2

HD9008.31: flange with sensor block \varnothing 14mm for duct sensors of the series TC and TO.

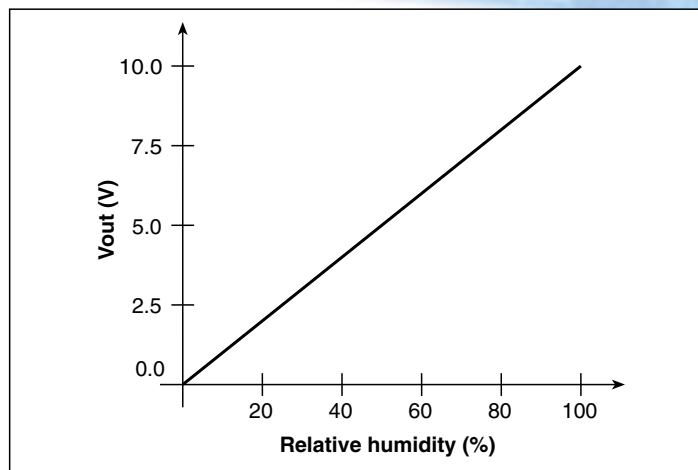

Fig. 7 0...10V relative humidity output

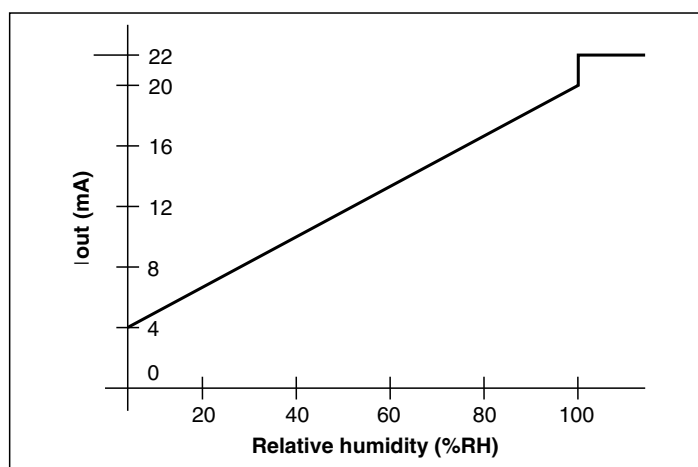

Fig. 8 4-20mA relative humidity output



Holder HD 9008.21.1 + HD 9008.26/14 250 mm.



HD 9008.31 flange with sensor block.