

Magnetic Rings for rotative measurements

The favorable alternative with small space requirement

- interpolation up to 22800 pulses/revolution possible
- direct assembly on axes possible (e. g. motor shaft)
- contactless and wear free measurement principle
- applicable in roughest environments (protection class IP67)
- vibration- and shock-resistant

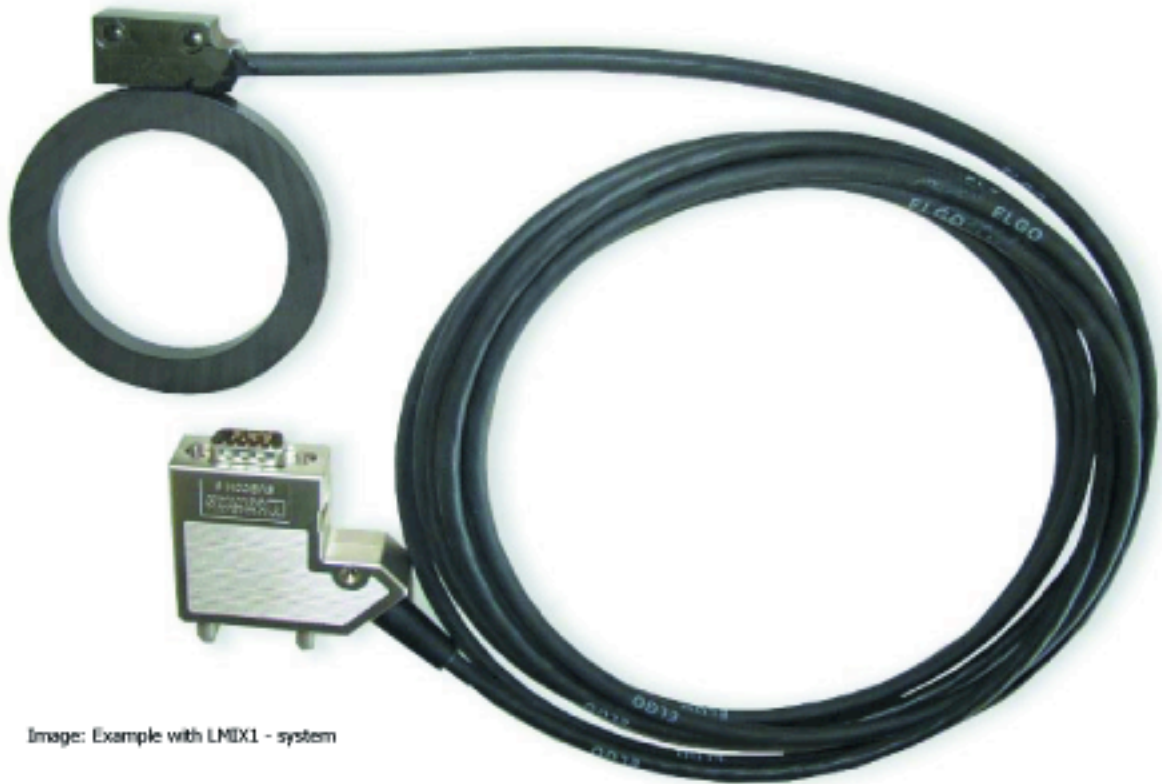

Image: Example with LMIX1 - system

1. GENERAL	3
2. ASSEMBLY WIT THE DIFFERENT SENSOR TYPES	4
2.1 Mounting with GMIX2	4
2.2 Mounting with GMIX1, LMIX1 or EMIX1	5
2.3 Mounting with LMIX2 or EMIX2	6
2.4 Mounting with LMIX3 or EMIX3	7
3. TECHNICAL SPECIFICATIONS	8
4. TYPE DESIGNATION	8
5. LIABILITY EXCLUSION / GUARANTEE	9

1. General

All the advantages of the magnetic measurement principle can be used by using magnet rings also for rotary movements e.g. revolutions -, angle or extent measurements.

Besides the magnet rings are a wear-free and space-saving alternative to optical rotary encoders and are insensitive against dirt, dust, liquids and vibrations also.

For scanning these magnet rings the conventional ELGO Incremental-Measuring-Systems of the product rows GMIX, LMIX and EMIX are useable.

The ring -provided with a magnetic pole division- (north/south poles) is scanned contactless with a magnetic sensor system. At present two different standard magnet ring sizes are available (on request customized variants are possible):

1. Big : outside diameter 72 mm's, inside diameter 54 mm's, width 7 mm's
2. Medium : outside diameter 38 mm's, inside diameter 31 mm's, width 6.5 mm's
3. Small : outside diameter 19.75 mm's, inside diameter 14.7 mm's, width 4.1 mm's

These can be referred in each case with the used sensor adapted pole division:

- Types with 5 mm pole length (for GMIX- and LMIX-Systems)
- Types with 2 mm pole length (for EMIX-Systems)

All information and data not contained in this description are available in the manual of the respectively selected sensor type.

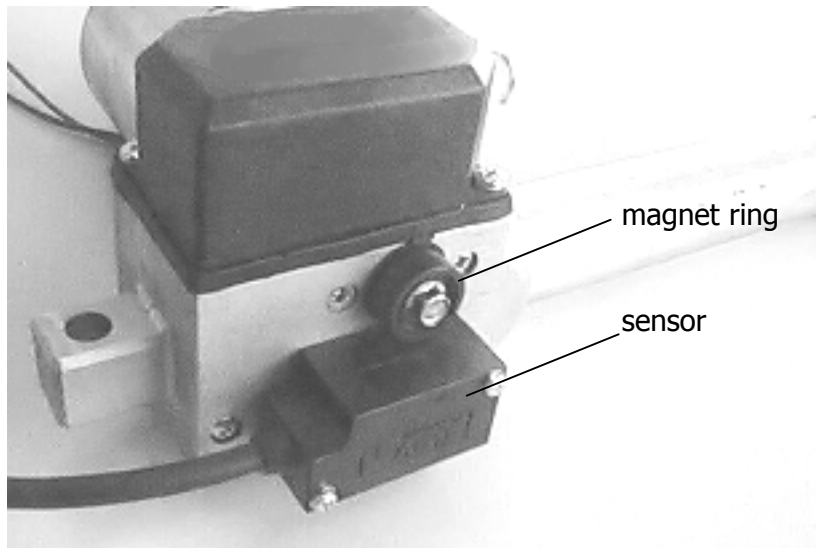

Image: Example - angular adjustment of a saw blade with LMIX3

2. Assembly with the different sensor types

Because the magnetized surface by the radius and the smaller width of magnet rings are substantially smaller than with the magnetic tape, it is to be paid attention here to the correct installation of the sensor head (active sensor areas) with the magnetic ring. The permitted distance of the sensors to the magnet ring is identical as with the magnetic tape assembly, however those must be considered the radius of the ring.

2.1 Mounting with GMIX2

It is to be made certain that **both active sensor surfaces*** shown here are covered within the permitted 4 mm distance. I.e. the radius and/or diameter of the ring must be selected in an accordingly size. The active sensor areas are represented in the following graph as hatched square.

Top view

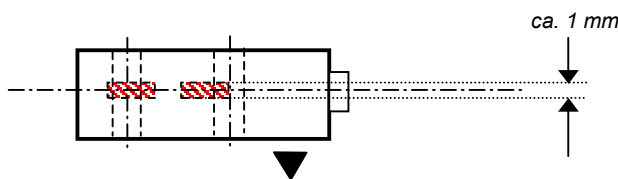

Side view

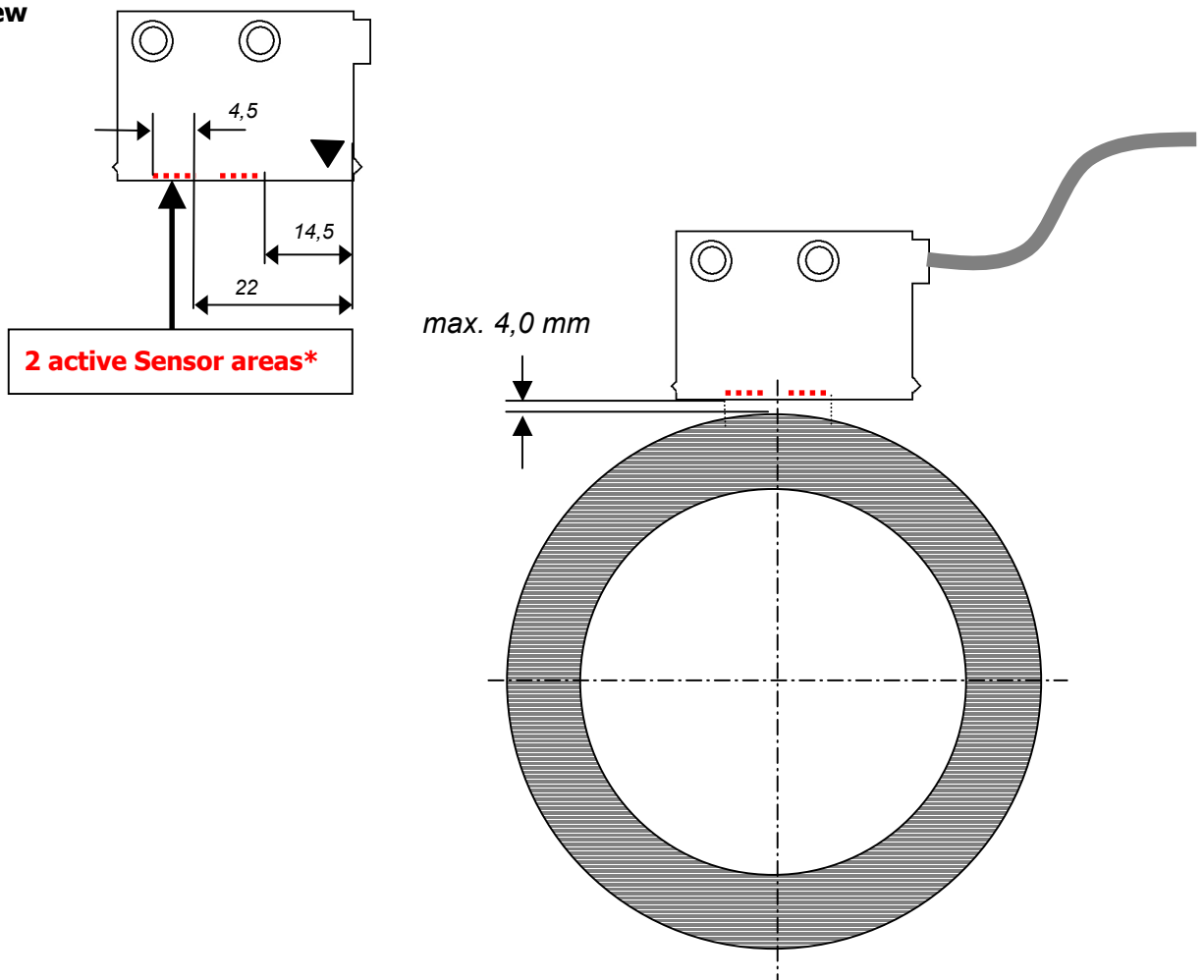

2.2 Mounting with GMIX1, LMIX1 or EMIX1

The active sensor area is represented in the following graph as hatched square.

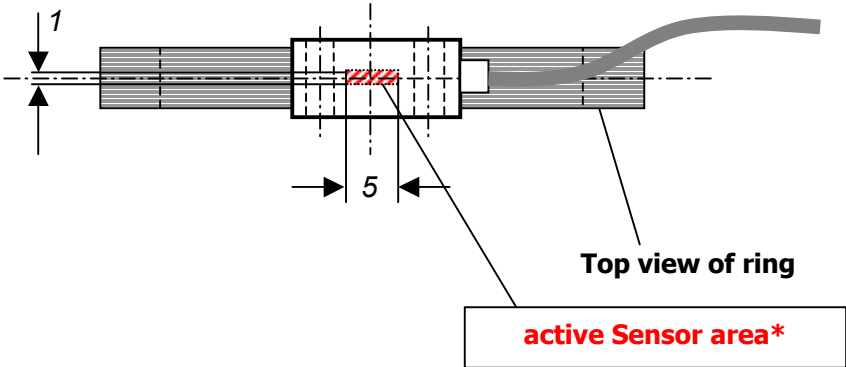

It is to be made certain that the entire active sensor surface* is within the permitted distance to the magnet ring.

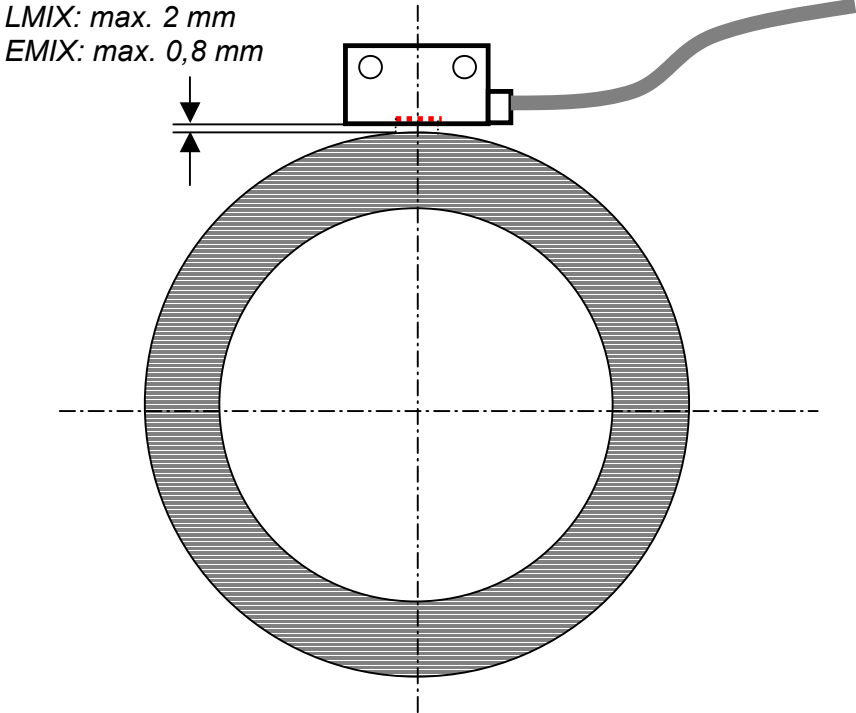

2.3 Mounting with LMIX2 or EMIX2

The active sensor area is represented in the following graph as hatched square.

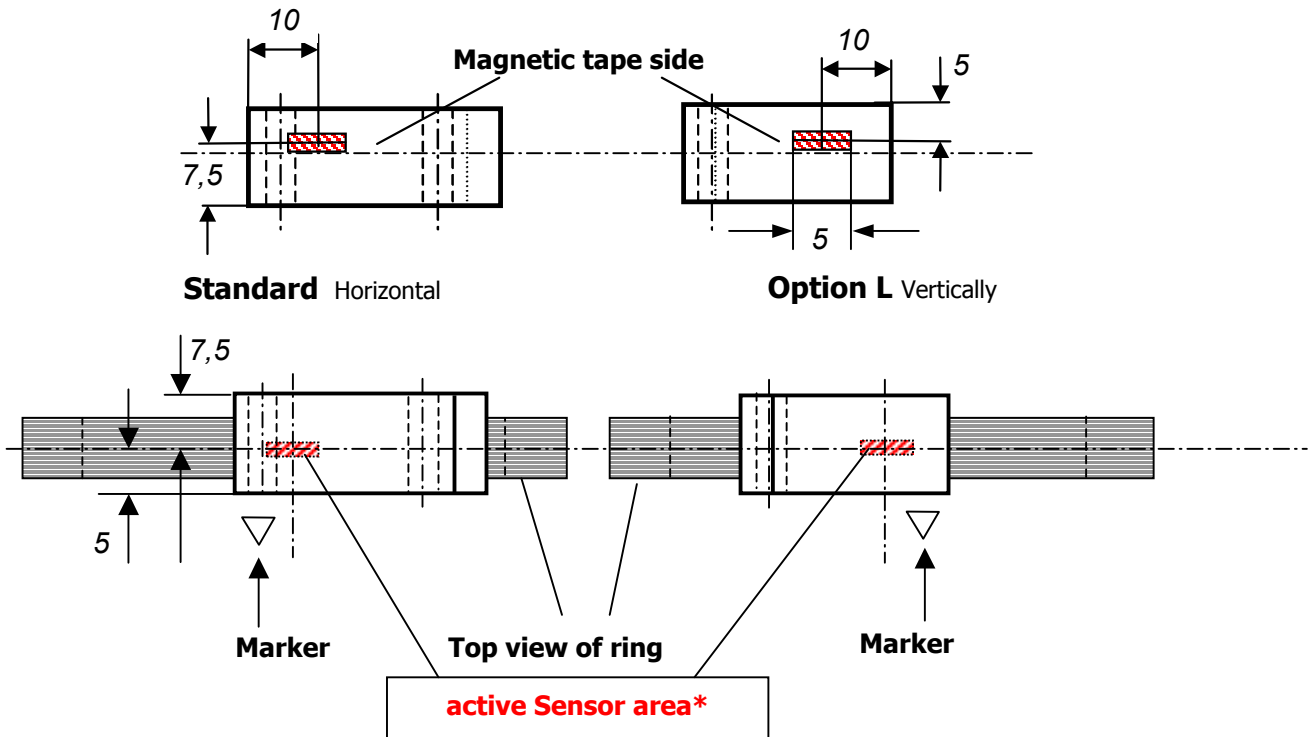

It is to be made certain that the entire active sensor surface* is within the permitted distance to the magnet ring.

Standard Horizontal

LMIX: max. 2 mm
EMIX: max. 0,8 mm

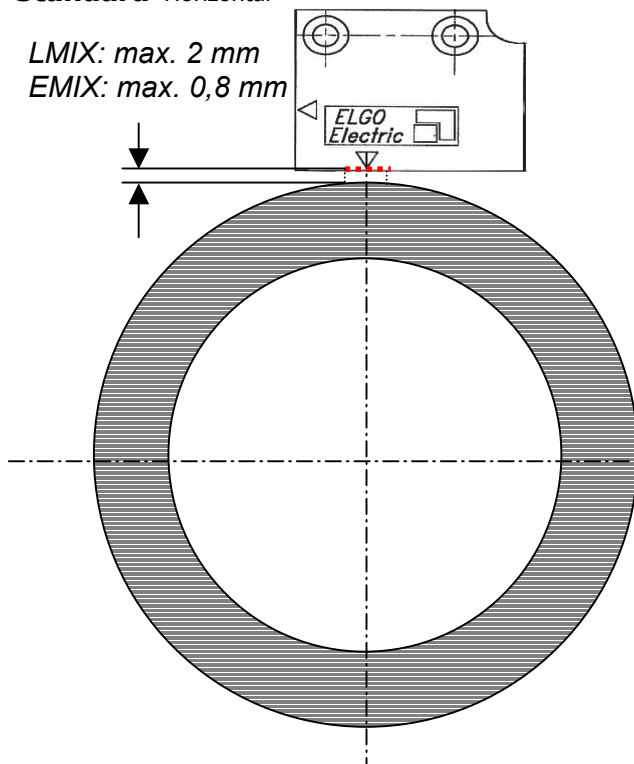

Option L Vertically

LMIX: max. 2 mm
EMIX: max. 0,8 mm

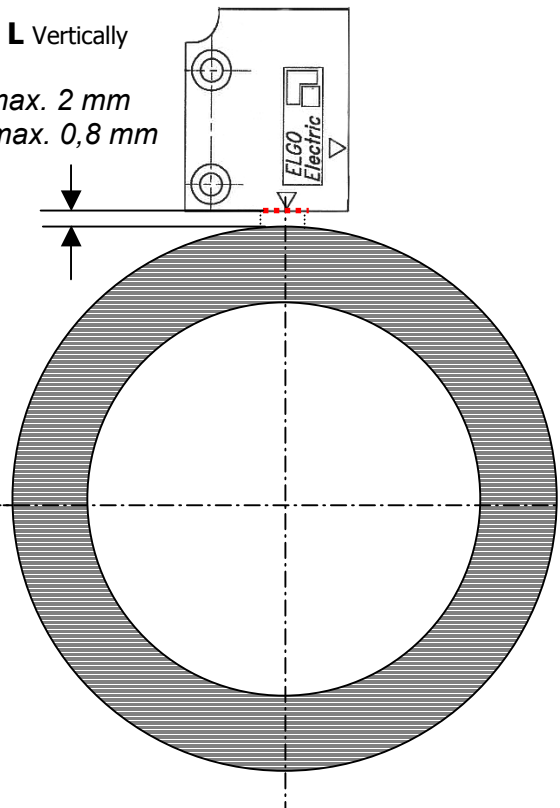

2.4 Mounting with LMIX3 or EMIX3

It is to be made certain that the entire active sensor surface* is within the permitted distance to the magnet ring. The active sensor area is represented in the following graph as hatched square.

Tolerances:
All measurements
+/- 0,1 mm

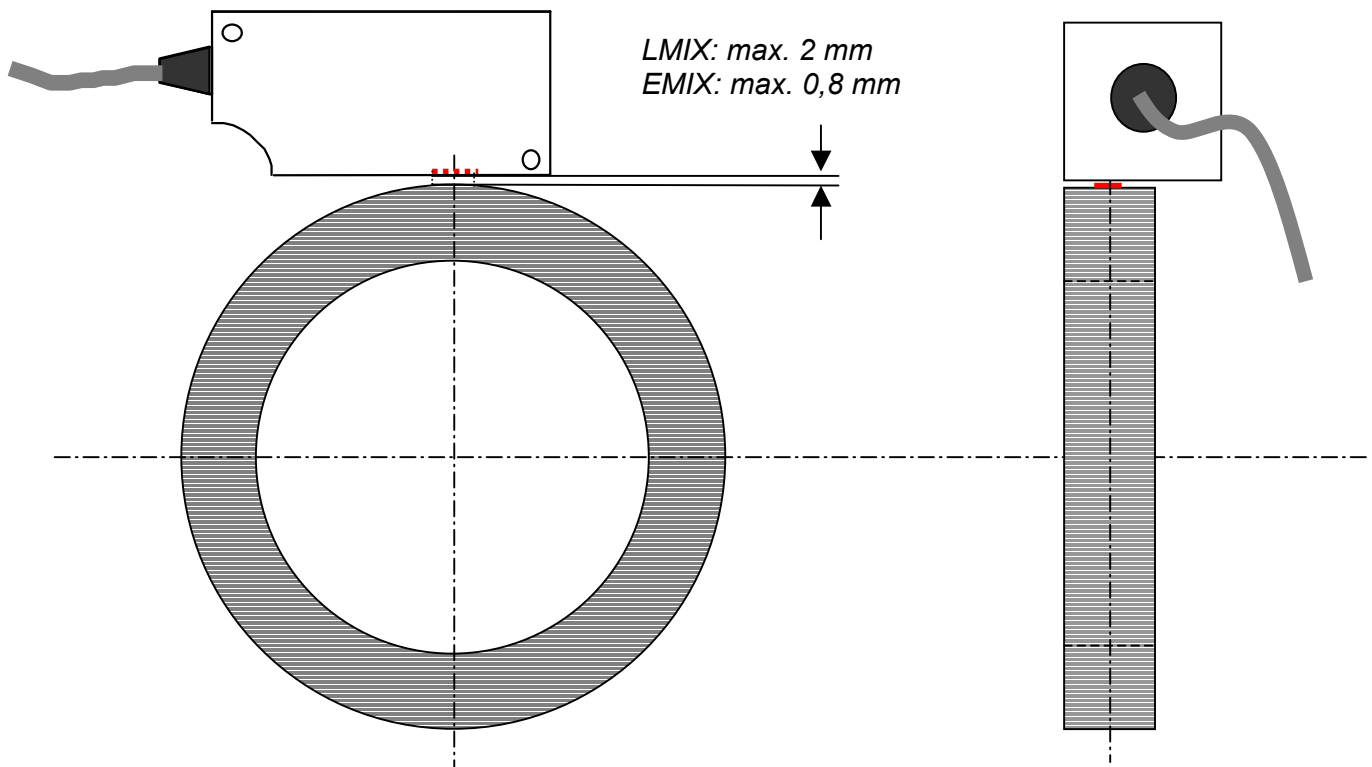
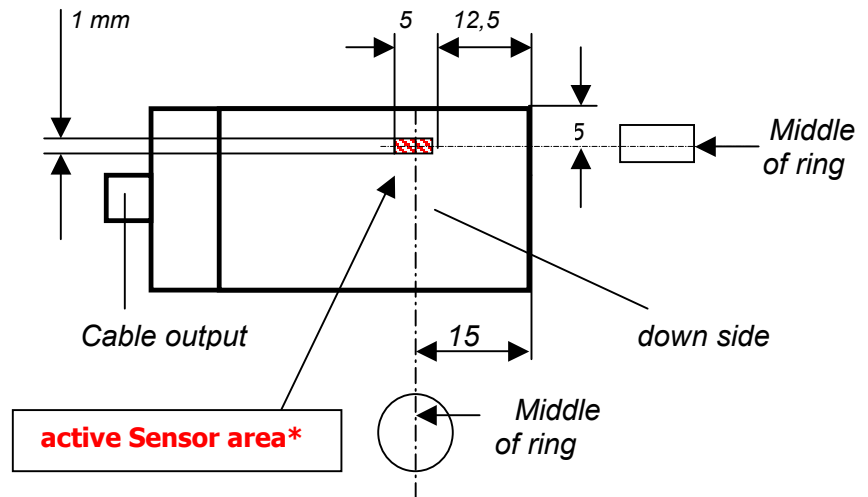

3. Technical specifications

Designation	MR2012	MR2030	MR3824	MR3860	MR7244	MR72114
Outer Ø in mm's	19,75 - 0.05	19,75 - 0.05	38 - 0.1	38 - 0.1	72 ±0.05	72 ±0.05
Inside Ø in mm's	14,7+0.2/-0.15	14,7+0.2/-0.15	30 ±0.5	30 ±0.5	54 ±0.8	54 ±0.8
Width in mm's	4,1 +0.05	4,1 +0.05	6,5 ±0.05	6,5 ±0.05	7 ±0.1	7 ±0.1
Number of poles / P	12	30	24	60	44	114
Pole width in mm's / pole	5	2	5	2	5	2
Pole width accuracy in %	< ± 1					
Total error	< 0.15° (standard) / < 0.007° (special applications)					
Material	Hard ferrite 8/22 according to DIN 17410, sintered isotrop					

Systems	LMIX1/2/3	EMIX1/2/3	GMIX1A	GMIX2
Interpolation factor / IF	200	200	500	2
max. pulse/r = IF x P	2400/4800/8800	6000/12000/22800	6000/12000/22000	24/48/88
All pulse numbers indicated here only valid, if all 4 edges are evaluated!				

4. Type designation

Magnet rings

MRXXXX

MR2012
MR3824 for LMIX and GMIX (5 mm's pole length)
MR7244

MR2030
MR3824 for EMIX (2 mm's pole length)
MR72114

At present three different mechanical sizes are available:

4.	Big	: Outside Ø 72 mm	Inside Ø 54 mm	Width 7 mm
5.	Medium	: Outside Ø 38 mm	Inside Ø 30 mm	Width 6,5 mm
6.	Small	: Outside Ø 19,7 mm	Inside Ø 14,7 mm	Width 4,1 mm

By use of reducing-rings are smaller inside-diameters possible too.